

# i-PAN7

---

## Preliminary Documentation ver 1.0



---

## 1.0 Introduction

---

The i-PAN7 is a flat panel ready to go solution, which may be easily integrated in customer devices. It consists of a 7" touch-display combined with a thin plastic housing including most peripherals needed by todays typical panel-applications. To make it easy for customers to attach their own peripherals or to put connectors on a desired place in a product, the i-PAN7 additionally has extensions connectors.

### **The device offers the following features:**

- WVGA (800 x 480) 7" TFT-display with touch
- Small plastic housing with mounting possibility
- Single Power supply, 7...16 Volt range
- SDIO/SD/MMC card socket
- USB Host
- 3-axis accelerometer
- Compass module
- 2,6W stereo speaker output
- 20 bit stereo headphone output
- Mic input (mono) for electret-capacitor microphones
- Analog video/camera input via mini BNC
- Quad-band GSM/GPRS modem
- GPS receiver
- Realtime clock

**Interfaces / Signals accessible over extension connectors:**

- 10/100 MBit Ethernet
- 2 x USB Host
- USB Slave
- I2C
- SD/MMC Card<sup>1</sup>
- RS232 COM1<sup>2</sup> FF\_UART
- RS232 COM2<sup>3</sup> BT\_UART (if GSM not used<sup>4</sup>)
- COM3<sup>5</sup> STD\_UART (if GPS not used<sup>6</sup>)
- RS485 (instead of COM2 BT\_UART<sup>7</sup>)
- Audio out
- Mic input (mono) for electret-capacitor microphones
- 3 x 10 bit ADC
- IrDA
- Programmable input and output pins (CPLD)
- CAN bus

---

**1. Please do not use the card socket on i-PAN7 and Connector Board at same time !  
This can cause data loss on the memory card !**

2. level converter: 24V
3. level converter: 24V
4. if mounted modem uses COM2 for communication with CPU
5. CPU signals: 3,3V
6. if mounted GPS module uses COM3 for communication with CPU
7. customer can choose between RS232 or RS485, see also note 3

FIGURE 1. Simplified Blockdiagram

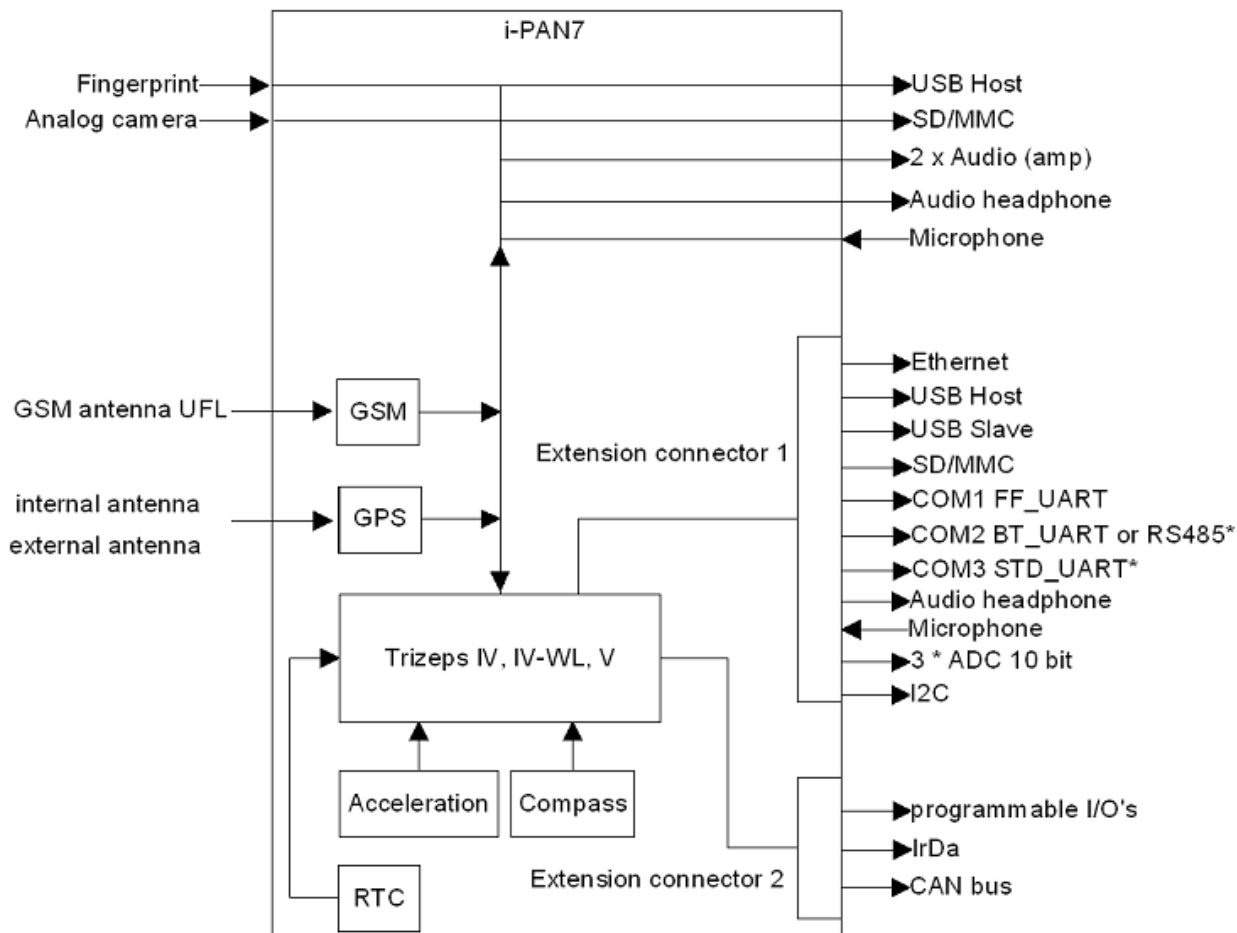

## 2.0 Connectors

TABLE 1.

Overview of all connectors on top side

Name	Function	Type
J1	LED Backlight	JST - SM02B-BHSS-1-TB
J2	Extension Connector 1	ERNI - SMC-B-80, Part No. 114806
J3	Audio out right	JST - SM02B-SRSS-TB
J4	LED Backlight	JST - SM02B-BHSS-1-TB
J5	Display OSD070TN83/84	40pin 0.5mm pitch bottom contact
J7	Display EDT ET070000DH6	40pin 0.5mm pitch bottom contact
J9	Mic/Audio in	Audio-Jack 3.5mm
J11	Video in	Mini BNC
J12	Extension Connector 2	ERNI - SMC-B-26, Part No. 054595
J13	Power in	Power Jack
J14	Sim Card	Push-push-connector
J15	Fingerprint	JST - 08FHJ-SM1-TB
J16	SD/MMC card	Push-push-connector
J19	CPLD programming	JST - 08FHJ-SM1-TB
J20	Display LG LB070WV1	40pin 0.5mm pitch bottom contact
J21	Headphone	Audio-Jack 3.5mm
J23	USB Host	Standard A
J24	Audio out left	JST - SM02B-SRSS-TB
J25	optional Power in	Phoenix - MSTBA2,5/2-G-5.08
J26	active GPS antenna	MCX
J30	Display touchscreen	JST - 04FMS-1.0SP-TF
J31	Display touchscreen	JST - 04FMS-1.0SP-TF

TABLE 2.

Connectors on bottom side

Name	Function	Type
J6	GSM antenna	UFL
J8	alternative extension connector 2	Samtec - FTSH Series, 26 pin
J22	alternative extension connector 1	Samtec - FTSH Series, 80 pin
J27	Ethernet	RJ45

## 2.1 Extension Connectors

The extension connectors offer a possibility to extend the functionality of the i-PAN7 to a custom specific requirement. All signals are listed in the following tables 3 and 4. Figure 3 shows how to identify the pins of the dual row type connectors. The bottom row is the A-row and the upper is the B-row.

FIGURE 2.

Connectors on i-PAN7



FIGURE 3.

Extension connectors pinout

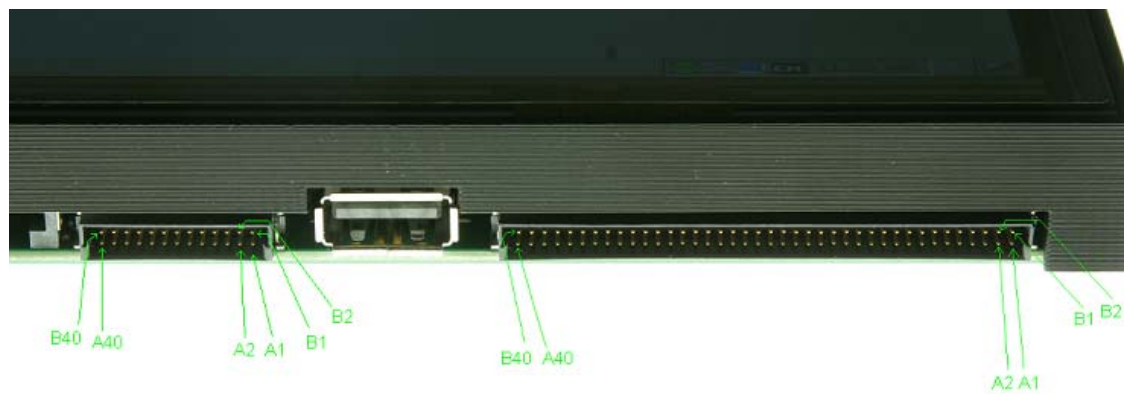

## 2.1.1 Extension Connector 1 (J2)

Pin	Signal	Pin	Signal	Function
A1	n.c.	B1	RJ45_RXI+	Ethernet
A2	ETH_AGND	B2	RJ45_RXI-	Ethernet
A3	ETH_AGND	B3	ETH_AGND	Ethernet
A4	ETH_AGND	B4	RJ45_TXO+	Ethernet
A5	ETH_AGND	B5	RJ45_TXO-	Ethernet
A6	\ETH_LINK_AKT	B6	\ETH_SPEED100	Ethernet
A7	ETH_GND1	B7	ETH_GND2	Ethernet
A8	GND	B8	GND	
A9	OTG_DP1	B9	OTG_DM1	USB Host 1
A10	OTG_DP2	B10	OTG_DM2	USB Host 2
A11	USB_HOST2_PWR	B11	USB_HOST1_GND	USB Host 1
A12	USB_HOST2_GND	B12	USB_HOST1_PWR	USB Host 2
A13	GND	B13	GND	
A14	I2C_DATA	B14	I2C_CLK	I2C
A15	+3V3	B15	+3V3	max. 500 mA
A16	+5V	B16	+5V	max. 500 mA
A17	HEADPHONE_GND	B17	VSSA_AUDIO	Audio
A18	HEADPHONE_R	B18	LINEIN_L	Audio
A19	HEADPHONE_L	B19	LINEIN_R	Audio
A20	AD0	B20	\RESET_OUT	ADC/Reset
A21	AD1	B21	AD3	ADC
A22	MMC_CMD_CON	B22	MMC_DAT3_CON	SD/MMC
A23	MMC_CLK_CON	B23	MMC_DAT2_CON	SD/MMC
A24	MMC_DET	B24	MMC_DAT1_CON	SD/MMC
A25	SD_WP	B25	MMC_DAT0_CON	SD/MMC
A26	GP00	B26	SD_EXT_PWR	
A27	GP85_HOLD_TR5_BLPWM	B27	GND	
A28	GND	B28	USB_SL_VCC	USB Slave
A29	USB_SL_D+	B29	USB_SL_D-	USB Slave
A30	COM2_CTS_V24	B30	COM2_RTS_V24	COM2
A31	COM2_TXD_485H	B31	COM2_RXD_485L	COM2/RS485
A32	GND	B32	GND	
A33	FF_RTS_V24X	B33	FF_DTR_V24X	COM1
A34	FF_DSR_V24X	B34	FF_TXD_V24X	COM1
A35	FF_RXD_V24X	B35	FF_CTS_V24X	COM1
A36	FF_RI_V24X	B36	FF_DCD_V24X	COM1
A37	RXD_2	B37	TXD_2	COM3
A38	GND	B38	GND	
A39	V_SUP_N	B39	V_SUP_P	External Power
A40	V_SUP_N	B40	V_SUP_P	External Power

### 2.1.2 Extension Connector 2 (J12)

Pin	Signal	Pin	Signal	Function
A1	IN7	B1	OUT7	CPLD I/O
A2	IN6	B2	OUT6	CPLD I/O
A3	IN5	B3	OUT5	CPLD I/O
A4	IN4	B4	OUT4	CPLD I/O
A5	IN3	B5	OUT3	CPLD I/O
A6	IN2	B6	OUT2	CPLD I/O
A7	IN1	B7	OUT1	CPLD I/O
A8	IN0	B8	OUT0	CPLD I/O
A9	IRDA_MODE	B9	IRDA_SD	IrDa
A10	+3V3	B10	+3V3	max. 500 mA
A11	GND	B11	GND	
A12	CAN_L	B12	CAN_H	CAN Bus
A13	GND_ISO	B13	GND_ISO	CAN Bus

## 3.0 GPIO functionality

TABLE 3.

GPIO's for custom use

Signal name	GPIO Trizeps IV	GPIO Trizeps V	Function / location
GP00	0	not usable	GPIO, J2-A26
FP_PWR_EN	13	16	Fingerprint enable, J15-7
GP85_HOLD_TR 5_BLPWM	85	13	GPIO, J2-A27
EN_GPS	107	57	enable GPS (active high)
GSM_POK	106	58	power ok for GSM
BL_PWM	11	17	PWM backlight
LED	50	5	dual color LED, low: red, high: yellow
DISP_EN	104	124	enable Display (active high)
EN_AUDIO	56	8 47k pullup	enable audio amplifier (active high)

## 4.0 Power supply

---

The i-PAN7 needs a nominal power supply of 12 Volt. The device will work stable in a power range of 7 ... 16 Volt. Applying a voltage more than 16 Volt will damage electronic components.

Usually connector J13 is equipped. The polarity is shown in figure 4.

---

**FIGURE 4.**

Polarity of J13



center pin diameter : 1.65mm, input hole diameter : 4.40mm

For a more ruggedized system or a rough industrial surrounding i-PAN7 can be provided with an alternative power connector (J25, see table 1).

### 4.1 Power consumption @ 12V

i-PAN7 LC, idle, full backlight: 340 mA

i-PAN7 LC, idle, normal backlight: 240 mA

### 4.2 Suspend current @ 12V

i-PAN7 LC with Ethernet: 20,5 mA

i-PAN7 LC no Ethernet: 2,8 mA

## 5.0 Outlines

### 5.1 PCB outlines top side

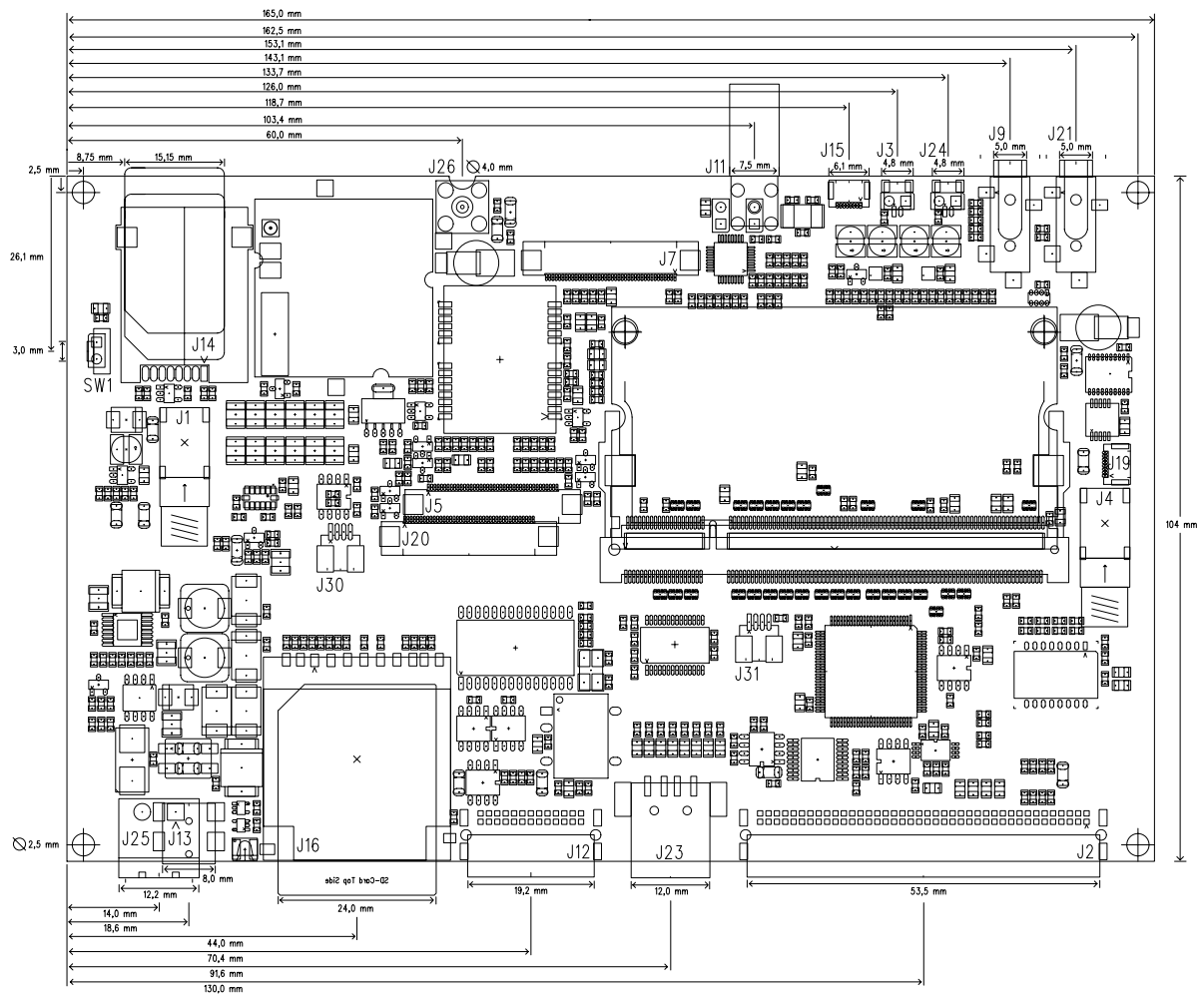
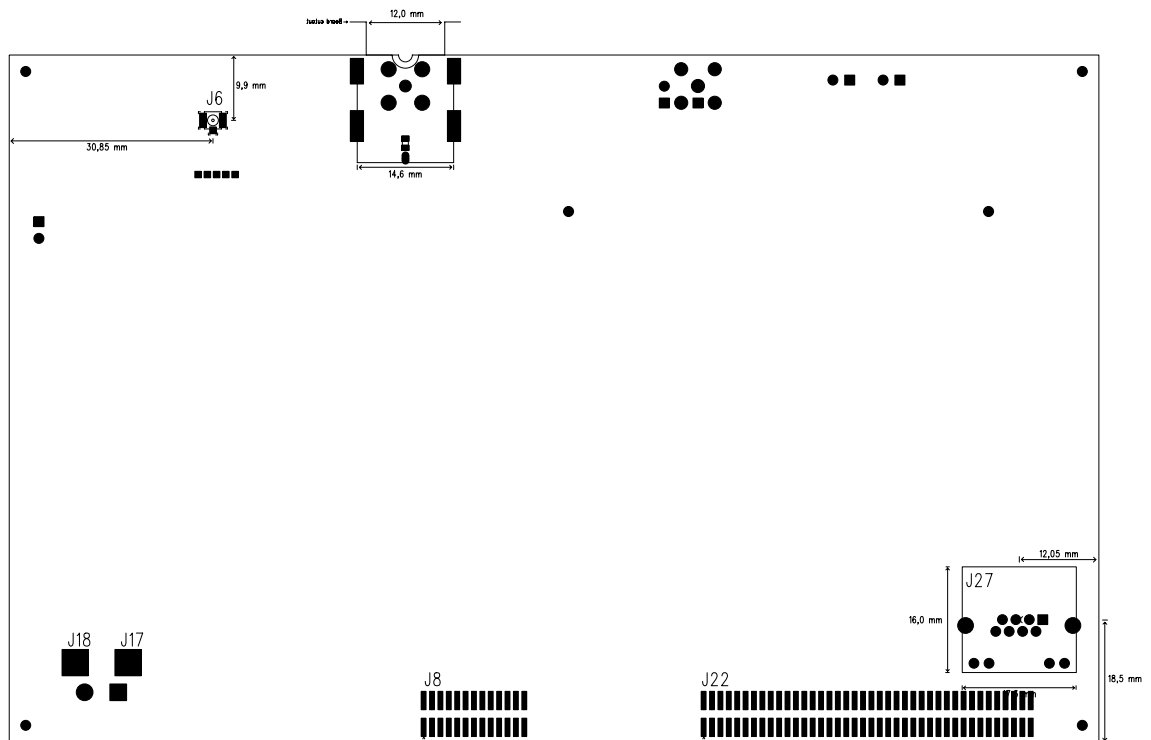

FIGURE 5.

PCB outlines top side

## 5.2 PCB outlines bottom side

FIGURE 6. PCB outlines bottom side



## 5.3 Outlines of device

The outlines of the device including the plastic housing are:

169 mm x 108 mm x 17 mm

## 6.0 Mounting

---

The housing of i-PAN7 is a small and thin frame. It has four mounting holes for 3 mm screws. Picture 7 shows the frame.

---

**FIGURE 7.**

Housing with mounting holes



## 7.0 Revision history

---

**TABLE 4.**

<b>Revision</b>	<b>date</b>	<b>changes</b>
1.0	2008.01.27	starting version (preliminary)

Please contact Keith & Koep for further information: [contact@keith-koep.com](mailto:contact@keith-koep.com) or visit our homepage at [www.keith-koep.com](http://www.keith-koep.com)